

Technical data sheet

BFC EXTRACTION BENCHES



BFC EXTRACTION BENCHES

Extraction benches equipped with electric fans.

They are suitable for the extraction of fumes and dust during the course of various metal welding processes and dry-machining material removal (grinding, frosting, polishing etc.)

The filter system consists of two BIA-certified hydro/oil-resistant polyester antistatic cartridges that allow very high degrees of separation with a high level of mechanical stability, resistance to humidity and temperature.

They come with an extraction grate on which to place the pieces being worked on and an internal dust-recovery tray.

They can be equipped with non-extracting protective bulkheads with or without protective glass or extraction bulkheads with anti-rebound fragment protection slats and an automatic cartridge cleaning system.

STANDARD BENCH TECHNICAL DATA

Item code	Model	DIMENSIONS (L x D x H) mm	POWER [KW]	POWER SUPPLY* [V] - [Hz]	FLOW RATE [m³/h]	NOISE LEVEL [dB(A)]
U35260068	BFC 1200	1210x850x920	1.5	400 - 50	1500	<70
U35260069	BFC 2000	2010x850x920	2.2	400 - 50	2300	<70

**Also available in an ATEX version*

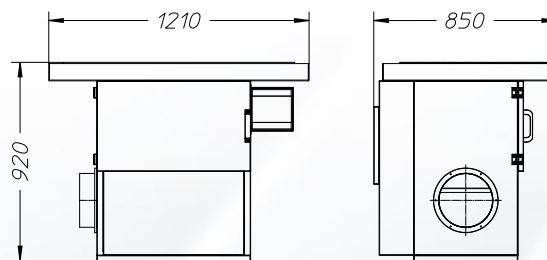

BFC 1200

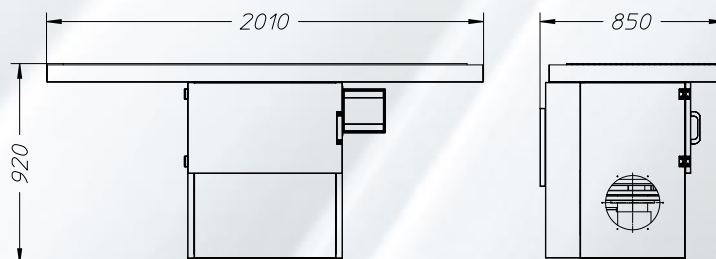

BFC 2000

Code	Description
U35260068	BFC 1200 EXTRACTION BENCH

STANDARD FEATURES

-	GRATE AND PLATFORM 1200x800
-	METALLIC PREFILTER
-	CARTRIDGES
-	ELECTRIC FAN 1.5 KW 400V
-	ON-BOARD ELECTRICAL PANEL

OPTIONAL

L16060008	EXTRACTION BULKHEADS H.500
L16060009	PROTECTIVE BULKHEADS H.500
S28240014	MECHANICAL FILTER BLOCKAGE DETECTOR
L16300090	SILENCER
S28240053	AUTOMATIC CLEANING KIT
L12100078	VERTICAL AIR DISCHARGE
D12100008	HORIZONTAL AIR DISCHARGE

Further customizations are possible. For information, please contact our sales office.

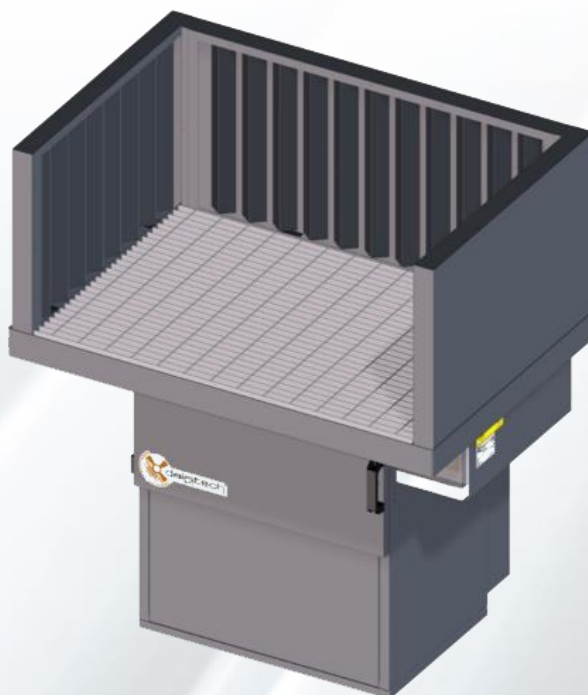

Code	Description
U35260069	BFC 2000 EXTRACTION BENCH

STANDARD FEATURES

-	GRATE AND PLATFORM 2000x800
-	METALLIC PREFILTER
-	CARTRIDGES
-	ELECTRIC FAN 2.2 KW 400V
-	ON-BOARD ELECTRICAL PANEL

OPTIONAL

L16060010	EXTRACTION BULKHEADS H.500
L16060011	PROTECTIVE BULKHEADS H.500
S28240014	MECHANICAL FILTER BLOCKAGE DETECTOR
L16300090	SILENCER
S28240053	AUTOMATIC CLEANING KIT
L12100078	VERTICAL AIR DISCHARGE
D12100008	HORIZONTAL AIR DISCHARGE

Further customizations are possible. For information, please contact our sales office.

